

Description:

Sentry Sprinklers **Model 7300** is a ductile iron, Wafer style, Resilient Seated, Spring loaded Check Valve. The valve allows water to flow in one direction and prevent flow in the opposite direction. The valve has a clear pathway for water to reduce pressure drop and allow maximum flow. The valve is anti-corrosion with 10 mil (250µ) of fusion-bonded epoxy (FBE) coating on both the inside & outside. All other components are made of corrosive resistance material. The valve is suitable for horizontal and/or vertical (upward flow only).

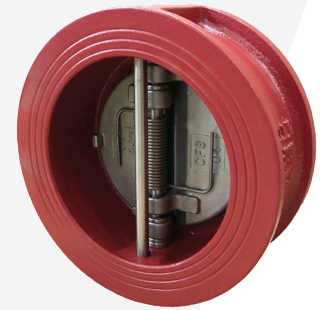

Model 7300



Features:

- Size 2" – 12" Maximum working pressure 300 PSI (20.7 Bar) @ -10° F - 248° F, (-10° C - 120° C).
- Ductile Iron body with end dimensions conforming to API594 Class 125.
- Connection ends ANSI B16.1 Class 125 or BS EN 1092-2 PN10/PN16.
- Meets all requirements for UL312 .
- Aluminum Bronze Disc against EPDM Sealing for durability.
- Epoxy coated inside & outside.
- Connection ends Wafer API594 Class 125. BS EN 1092-2 PN10/PN16.
- Connection end available in Wafer-by-Wafer (WW).

Dimensions:

INCH (DN) inch (mm)	H inch (mm)	Ø D inch (mm)	Ø D1 inch (mm)	Ø A
2 (50)	2.12 (54)	2.75 (70)	1.77 (45)	CL125/PN10/PN16
2.5 (65)	2.36 (60)	3.5 (89)	2.5 (63)	CL125/PN10/PN16
3 (80)	2.64 (67)	3.86 (98)	2.6 (66)	CL125/PN10/PN16
4 (100)	2.64 (67)	4.76 (121)	3.87 (92)	CL125/PN10/PN16
5 (125)	3.27 (83)	5.7 (145)	4.7 (119)	CL125/PN10/PN16
6 (150)	3.74 (95)	6.7 (170)	5.63 (143)	CL125/PN10/PN16
8 (200)	5 (127)	8.58 (218)	6.95 (176)	CL125/PN10/PN16
10 (250)	5.5 (140)	10.43 (265)	9 (228)	CL125/PN10/PN16
12 (300)	7.12 (181)	12.2 (310)	9.88 (250)	CL125/PN10/PN16

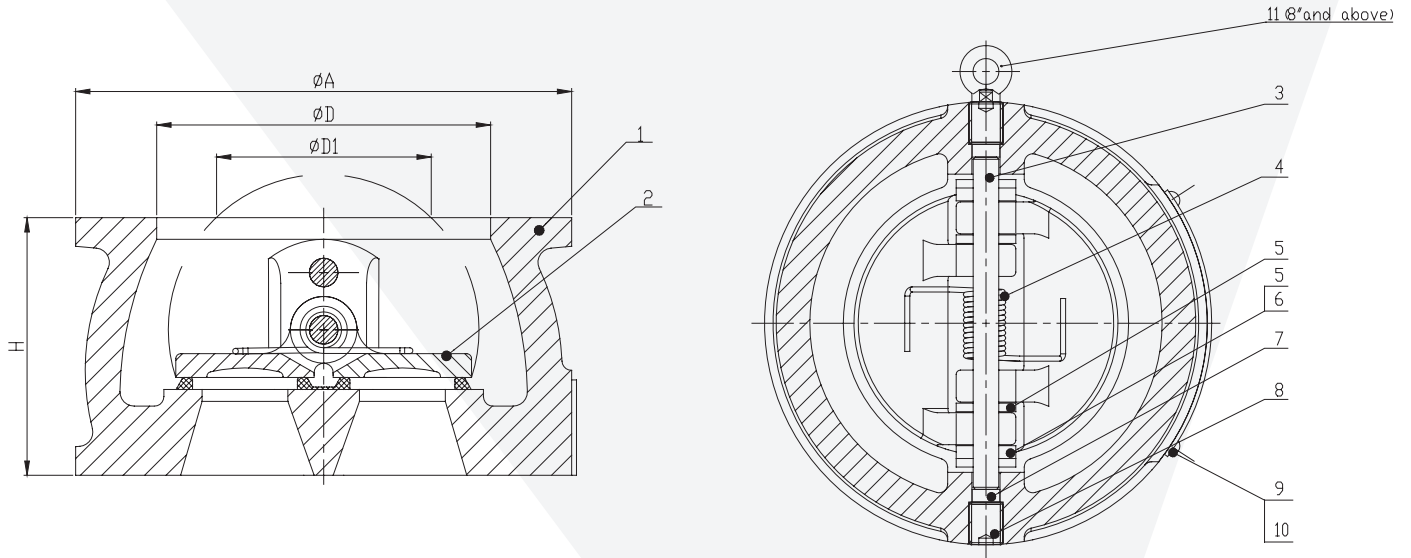

Material List:

ITEM	NAME	MATERIAL
1	Body	DI+EPDM
2	Disc	CF8/CF8M/C95400
3	Stem	SS304/CF8M
4	Spring	SS304
5	Washer	SS304/PTFE
6	Gasket	SS304/PTFE

ITEM	NAME	MATERIAL
7	Sealing	EPDM
8	Plug	Blackening of carbon steel
9	NamePlate	SS304
10	Rivet	C.S
11	Lift Ring	Carbon Steel
-	-	-

SIZE CODE	2" (50)	2.5" (65)	3" (80)	4" (100)	5" (125)	6" (150)	8" (200)	10" (250)	12" (300)
	020	025	030	040	050	060	080	100	120

Flange CODE	CLASS ANSI 125 → A	CLASS ANSI 150 → B	CLASS PN10 → C	CLASS PN16 → D
-------------	--------------------	--------------------	----------------	----------------

ORDER KEY	END CONNECTION →				← FLANGE CODE			
	MODEL # →	7300-	WW-	X-	XXX	←	SIZE CODE	