

Description:

Sentry Sprinklers Model SY8152 is an Automatic, Quick Response, Concealed Pendent Sprinkler head that utilizes a frangible thermo-sensitive glass bulb to operate the sprinkler. The sprinkler is available in various finishes and temperatures. Sprinkler Model SY8152 is listed and approved for standard coverage for Light and Ordinary hazards. Model SY8152 is a 5.6 K-factor (80 metric) Sprinkler that is intended for use in fire sprinkler systems designed in accordance with the standard installation rules recognized by the applicable listings or approved agency. The Concealed Pendent Sprinkler Assembly consists of the Sprinkler Frame and the Cover Plate Assembly. The Cover Plate Assembly is mounted to the Sprinkler Frame. Upon the release of the Cover Plate from the Cover Plate Assembly and the break of the sprinkler Glass Bulb, the sprinkler produces a hemispherical water distribution pattern below the deflector.

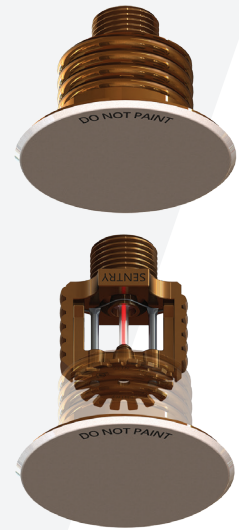

Model SY8152



Technical Data:

Minimum Operating Pressure:	7 PSI (0.5 bar)
Maximum Working Pressure:	175 PSI (12 bar)
Factory Test:	100% @ 500 PSI (34.5 bar) Hydrostatically
Nominal K-Factor:	5.6 (80 metric)
Thread Size:	1/2" NPT
Bulb Size:	3 mm

Operation:

Upon fire initiation within a protected hazard, the temperature inside the hazard rises melting the solder between the cover plate and its assembly. A spring on the Sprinkler Cover Plate Assembly ensures the ejection of the cover plate from its assembly. The release of the Cover Plate enables the Sprinkler Deflector to descend to a level below the ceiling. The rising heat within the protected hazard causes the liquid inside the Thermo-Sensitive bulb to expand. The liquid expansion causes the glass bulb to break, releasing the bulb seat assembly. The water discharges through the sprinkler orifice striking the deflector, producing a uniform distribution pattern within the hazard area.

Coverage:

For coverage area and placement of the sprinkler refer to NFPA 13 standard.

Guarantee:

Sentry Sprinklers shall replace any of its products if found to be defective in materials or workmanship for a period of one year from order date. The guarantee does not cover wear and tear or improper installation.

Marking and Dimension:

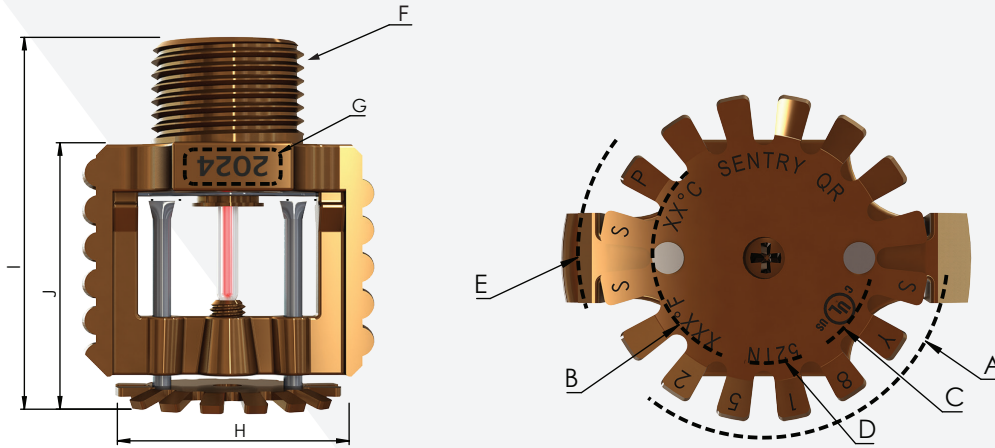

ITEM	DESCRIPTION	IDENTIFICATION
A	Sprinkler Identification Number (SIN)	SY8152
B	Sprinkler Temperature (XXX ° F / XXX ° C)	AS MARKED
C	Approvals	AS MARKED
D	Manufacturing Location	52TN
E	Sprinkler Type	Standard Spray Pendent (SSP)
F	Sprinkler Pipe Fitting	1/2"
G	Manufacturing Year	AS MARKED
H	Deflector Diameter	1 3/16" (30.00mm)
I	Sprinkler Frame Length	1 7/8" (47.50mm)
J	Sprinkler Height	1 23/64" (34.50mm)

Sprinkler Component:

ITEM	DESCRIPTION	MATERIAL
1	Screw	Brass
2	Deflector	Brass
3	Sprinkler Frame	Brass
4	Bulb	3 MM Glass With Glycerin Solution
5	Bulb Seat	Teflon
6	Plug/Seat Assembly	Bronze
7	Spring	Stainless Steel
8	Plug Seal	Teflon Tape

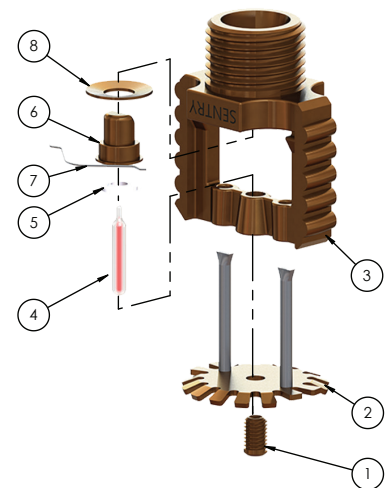

Installation:

All sprinkler heads must be inspected prior to installation. If a sprinkler is damaged, the bulb is cracked, the bulb has loss of liquid and or lost its protective cap, do not install the sprinkler and contact Sentry Sprinklers for replacement. With the sprinkler held in the horizontal position, a small air bubble should be present inside the glass bulb.

Use Sentry Sprinklers recommended wrench to install the sprinkler. Slide the sprinkler wrench around the sprinkler frame arms and press the wrench down to engage sprinkler wrench flats. Rotate the wrench clockwise to tighten the sprinkler head. The frame arms must be parallel to the pipe. Never tighten the sprinkler from sprinkler arms. Any torque applied to the frame arms will dislodge the bulb seating assembly causing the sprinkler to leak.

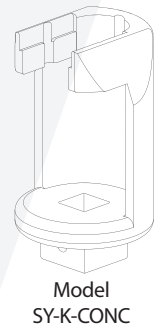

The Concealed Sprinkler must not be used in any application where the air pressure above the ceiling is greater than that below it. Downdraft through the Cover Plate Assembly could delay sprinkler operation in a fire condition. Exercise caution when installing the sprinkler. If the sprinkler is damaged during installation, do not attempt to fix it, replace it immediately.

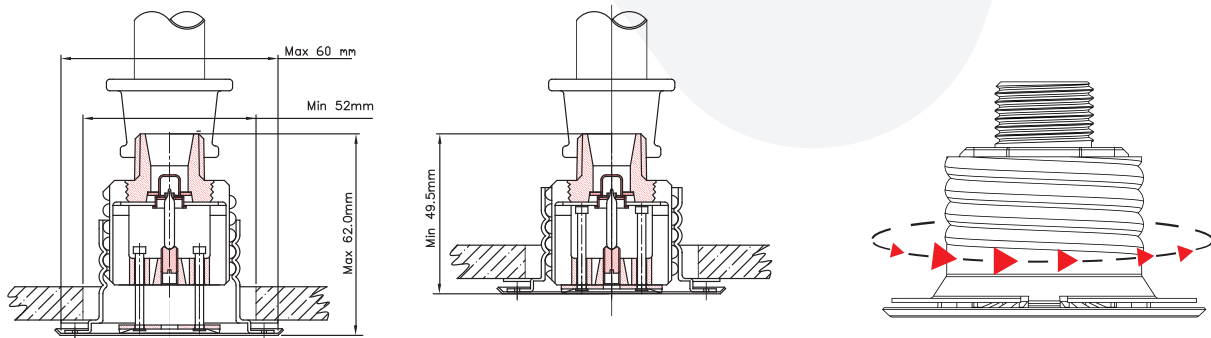

After the ceiling has been completed with a 2.05" (52mm) to 2 3/8" (60mm) diameter clearance hole, remove and discard the Protective Cap (Blue) and verify that the sprinkler is intact. Use the Cover Plate Assembly to gently thread/screw it onto the Concealed Sprinkler Frame until it firmly engages the ceiling. The Cover Plate Assembly has a maximum 1/2" (12.50 mm) adjustability to Sprinkler Frame engagement clearance.

Do not attempt to make up for insufficient adjustment in the sprinkler assembly by overtightening the Sprinkler Cover Plate Assembly to the Concealed Sprinkler Frame.

Instead, readjust the position of the sprinkler fitting.

Absence of the Cover Plate Assembly may delay the sprinkler operation time in a fire situation.

For additional details, refer to NFPA and UL for installation guidelines.

Care and Maintenance:

The owner is responsible for maintaining their fire protection system and devices in proper operating condition. Refer to NFPA 25 for inspection, testing and maintenance requirements. It is recommended that an automatic sprinkler system be inspected quarterly by qualified inspection personnel.

Sprinklers must never be shipped and or stored where ambient temperature exceeds 100° F / 38°C. Inspect Sprinkler before and after installation. Exercise caution during installation to avoid damage to the sprinkler. Damaged sprinkler due to dropping, striking, and or wrench slippage must be replaced.

If a sprinkler must be removed for any reason, do not reinstall it without reinstalling the Cover Plate Assembly. If a Cover Plate Assembly becomes dislodged during service, replace it immediately.

Properly installed sprinklers must have a nominal 3/32" (2.4mm) air gap between the lip of Cover Plate and the ceiling. The air gap is necessary for the proper operation of the sprinkler. If the ceiling is to be painted after installation of the Cover Plate Assembly, care must be taken to ensure that new paint does NOT seal off the nominal 3/32" (2.4mm) air gap.

Sprinklers and or cover plates must not be painted, coated or otherwise altered after leaving the factory. Sprinklers that have been exposed to corrosive products of combustion, but have not operated, must be replaced.

Concealed Pendent Sprinkler				
SIN + TEMPERATURE + FINISH CODE				
Part	SY8152135*	SY8152155*	SY8152175*	SY8152200*
K-factor	5.6 (80 Metric)	5.6 (80 Metric)	5.6 (80 Metric)	5.6 (80 Metric)
Orientation	Concealed	Concealed	Concealed	Concealed
Response	Quick	Quick	Quick	Quick
Temperature	135° F (57° C)	155° F (68° C)	175° F (79° C)	200° F (93° C)
Bulb Color	Orange	Red	Yellow	Green
Temp. Classification	Ordinary	Ordinary	Intermediate	Intermediate
Hazard Type	Light/Ordinary	Light/Ordinary	Light/Ordinary	Light/Ordinary
Approval	UL	UL	UL	UL
Threads	1/2" NPT	1/2" NPT	1/2" NPT	1/2" NPT

* Finish Code: 1 For Brass

Cover Plate Part Number		
Part	CP81135-S-*	CP81155-S-*
Temperature	135° F (57° C)	155° F (68° C)
Adjustment	1/2" (12.5mm)	1/2" (12.5mm)

* Finish Code: C For Chrome, W For White (RAL # 9010) or RAL # Required

