

### Description:

Sentry Sprinklers Model SY8022 is an Automatic and or Open Quick Response, Pendent and Recessed Pendent Sprinkler head that utilizes a frangible thermo-sensitive glass bulb to operate the sprinkler. The sprinkler is available in various finishes and temperatures.

Sprinkler Model SY8022 is listed and approved for standard coverage for Light and Ordinary hazards. Model SY8022 is a 5.6 K-factor (80 metric) Sprinkler that is intended for use in fire sprinkler systems designed in accordance with the standard installation rules recognized by the applicable listings or approved agency. The Pendent Sprinkler produces a hemispherical water distribution pattern below the deflector.



Model SY8022



### Technical Data:

Minimum Operating Pressure:	7 PSI (0.5 bar)
Maximum Working Pressure:	175 PSI (12 bar)
Factory Test:	100% @ 500 PSI (34.5 bar) Hydrostatically
Nominal K-Factor:	5.6 (80 metric)
Thread Size:	1/2" NPT
Bulb Size:	3 mm

### Operation:

Upon fire initiation within a protected hazard, the temperature inside the hazard rises causing the liquid inside the Thermo-Sensitive bulb to expand. The liquid expansion causes the glass bulb to break, releasing the bulb seat assembly. The water discharges through the sprinkler orifice striking the deflector, producing a uniform distribution pattern within the hazard area.

### Coverage:

For coverage area and placement of the sprinkler refer to NFPA 13 standard.

### Guarantee:

Sentry Sprinklers shall replace any of its products if found to be defective in materials or workmanship for a period of one year from order date. The guarantee does not cover wear and tear or improper installation.

### Marking and Dimension:

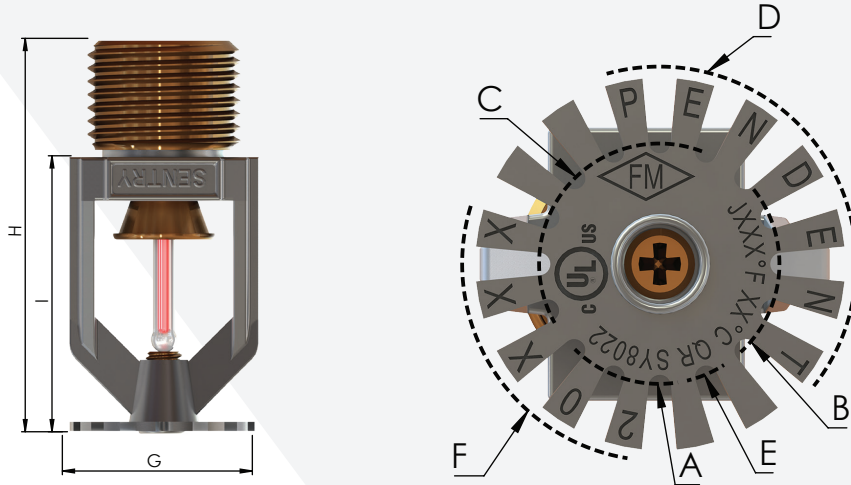

ITEM	DESCRIPTION	IDENTIFICATION
A	Sprinkler Identification Number (SIN)	SY8022
B	Sprinkler Temperature (XXX ° F / XXX ° C)	AS MARKED
C	Approvals	AS MARKED
D	Sprinkler Type	Pendent Standard Spray
E	Sprinkler Response	Quick Response
F	Manufacturing Year	AS MARKED
G	Deflector Diameter	1 1/16 " (26.2mm)
H	Sprinkler Frame Length	2 3/16" (55.36mm)
I	Sprinkler Height	1 1/2" (38.75mm)

### Sprinkler Component:

ITEM	DESCRIPTION	MATERIAL
1	Screw	Brass
2	Deflector	Brass
3	Sprinkler Frame	Brass
4	Bulb	3 MM Glass With Glycerin Solution
5	Bulb Seat	Teflon
6	Plug	Bronze
7	Plug Seal	Teflon Tape

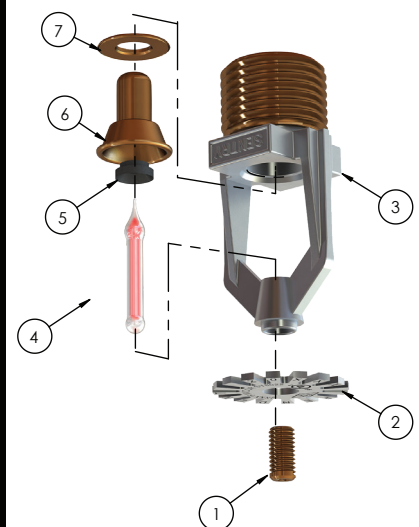

### Installation:

All sprinkler heads must be inspected prior to installation. If a sprinkler is damaged, the bulb is cracked, the bulb has loss of liquid and or lost its protective strap, do not install the sprinkler and contact Sentry Sprinklers for replacement. With the sprinkler held in the horizontal orientation, a small air bubble should be present inside the glass bulb.

Use Sentry Sprinklers recommended wrench to install the sprinkler. Slide the sprinkler wrench around the sprinkler frame arms and press the wrench down to engage sprinkler wrench flats. Rotate the wrench clockwise to tighten the sprinkler head. The frame arms must be parallel to the pipe. Never tighten the sprinkler from sprinkler arms. Any torque applied to the frame arms will dislodge the bulb seating assembly causing the sprinkler to leak.

**Do not remove the sprinkler strap until the sprinkler system is under commissioning for operation.**

**For additional details, refer to NFPA and UL for installation guidelines.**

### Care and Maintenance:

The owner is responsible for maintaining their fire protection system and devices in proper operating condition. Refer to NFPA 25 for inspection, testing and maintenance requirements.

It is recommended that an automatic sprinkler system be inspected quarterly by qualified inspection personnel.

Sprinklers must not be painted, coated or otherwise altered after leaving the factory.

Sprinklers that have been exposed to corrosive products of combustion, but have not operated, should be replaced.

**Note:**

Absence of an escutcheon, which is used to cover a clearance hole, may delay sprinkler operation time in a fire situation.

Pendent Sprinklers				
SIN + TEMPERATURE + FINISH CODE				
Part	SY8022135*	SY8022155*	SY8022175*	SY8022200*
K-factor	5.6 (80 Metric)	5.6 (80 Metric)	5.6 (80 Metric)	5.6 (80 Metric)
Orientation	Pendent	Pendent	Pendent	Pendent
Response	Quick	Quick	Quick	Quick
Temperature	135° F (57° C)	155° F (68° C)	175° F (79° C)	200° F (93° C)
Bulb Color	Orange	Red	Yellow	Green
Temp. Classification	Ordinary	Ordinary	Intermediate	Intermediate
Hazard Type	Light/Ordinary	Light/Ordinary	Light/Ordinary	Light/Ordinary
Approval	UL/FM	UL/FM	UL/FM	UL/FM
Threads	1/2" NPT	1/2" NPT	1/2" NPT	1/2" NPT

\* Finish Code: 1 For Brass, 2 For Chrome

This Page Intentionally Left Blank